

Operating Instructions
Parts List

Manuel d'utilisation
Nomenclation



Note: Do not use the platform stacker before reading and understanding these operation instructions.

Remarque: Propriétaire et utilisateur doivent lire attentivement ce manuel avant toute utilisation de cette transpalette.

ATTENTION:

- 1. Environmentally hazardous waste, such as batteries and electronics, will have a negative effect on the environment, or health, if handled incorrectly.**
- 2. The waste packages should be sorted and put into solid dustbins according to the materials and be collected disposal by local special environment protection bureau. To avoid pollution, it's forbidden to throw away the wastes randomly.**
- 3. To avoid leaking during the use of the products, the user should prepare some absorbable materials (scraps of wooden or dry duster cloth) to absorb the leaking oil in time. To avoid second pollution to the environment, the used absorbable materials should be handed in to special departments in terms of local authorities.**

Thank you for using platform stacker. Your stacker is made of high quality steel and is designed for the horizontal lifting and transport of loads on a pallet or standardized containers on a level, fixed base. For your safety and correct operation, please carefully read this instruction before using it.

NOTE: All of the information reported herein is based on data available at the moment of printing. We reserves the right to modify our own products at any moment without notice and liability in any sanctions. So, it is suggested to always verify possible updates and changes.

1. GENERAL SPECIFICATIONS

Type	Capacity (Kg)	Size of platform (mm)	Min. / Max. fork height (mm)	Caster Dia. (mm) (PU)	Front roller Dia. (mm) (PU)	Battery	Motor
EPS0412	400	650X576	85-1200	Φ 127x40	Φ 75x40	DC12V / 60Ah	DC12V / 700W
EPS0415			85-1500				

Type	Capacity (Kg)	Size of platform (mm)	Min. / Max. platform height (mm)	Caster Dia. (mm) (Rubber)	Front roller Dia. (mm) (Rubber)	Battery	Motor
EFP0412	400	650X550	200-1200	Φ 150x40	Φ 150x45	DC12V / 60Ah	DC12V / 700W
EFP0415			200-1500				

2. INTENDED USE

The hydraulic stacker, with forks / platform for independent lifting of loads, is intended for power lifting, manual lowering and the manual transporting of loads. **Its use requires a level and firm floor/ground surface.**

The hydraulic stacker, with forks/platform for independent lifting of loads, is intended for on-site transporting of unit loads, e.g. in warehouses associated with industry and delivery companies etc., for short range transporting of standard and wire mesh pallets as well as other palletised loads.

It is not suitable for use in potentially explosive locations.

It is not suitable for use in hostile environments.

Alterations to the hydraulic stacker and the addition of auxiliary units are only permitted with our express written approval.

Ensure that you take note of the technical data and details on functional characteristics!

3. Regulations for prevention of accidents

The hydraulic stacker must be used and operated as intended and in accordance with relevant regulations.

The current regulations of the country in which it is used must be complied with 1)

In Germany these are currently:

German UVV safety standard BGV D27 (available from Carl Heymanns Verlag, Cologne, Berlin)

EC Directive EN 1757-1

EC Directive 98/37/EC

1) in the respective current version

It is absolutely essential that the operating instructions below and the BGV D27 regulations for prevention of accidents are carefully read through before starting use.

4. Safety instructions

Operation, assembly and maintenance only by: Instructed, qualified operators

(Definition of qualified operators in accordance with IEC 364)

Qualified operators are persons who, on the basis of their training, experience, instruction and knowledge of the relevant standards and regulations, regulations for prevention of accidents and operating conditions, are authorised by the persons responsible for the safety of the plant to carry out the respective required tasks whilst being able to recognise and prevent potential associated dangers.

- Operation is only permitted on a level and firm floor/ground surface.
- Transporting of persons and a presence within the danger zone is not permitted.
- A presence under a raised load is not permitted.
- The specified load capacity must not be exceeded.
- The loaded material must be distributed evenly on the fork/platform.
- The hydraulic stacker must never be loaded whilst the fork/platform is in a raised position.
- The stacker is not made for or capable of off-loading like a fork lift truck or crane.
- Never leave the load unattended in a raised position.
- Never reach into moving parts.
- Defects are to be dealt with competently as soon as they become apparent.
- Only use genuine spare parts.

Inspections

In accordance with Section 37 of the BGV D27 the hydraulic stacker must be inspected by a competent technical expert at least once per year, and otherwise as required.

We recommend that you record the results of the inspections in an inspection book.

5. Operating instructions

Functional description

The fork / platform stacker is a manually-operated hydraulic device.

Handling

Before taking into operation, check:

- perfect function of the operating elements
- function of the parking brake
- state of the travelling rollers and roller axles
- load chains for adjustment, chain tension and wear



Parking brake

One or two steering wheel of the hydraulic stacker is equipped with a parking brake. For depositing, actuate the parking brake.

Picking up a load

Check that the load does not exceed the loading capacity of the hydraulic stacker.

Roll the hydraulic stacker slowly up to the pallet/load. Roll the fork prongs under the pallet until the back end of the fork rests against the load (pallet). Lift the load by operating the control stick.

The load must be evenly distributed across both prongs of the fork / platform.
The load centre of gravity must not be exceeded.

Moving with the load

As only a parking brake is provided, the hydraulic stacker must not be operated uphill and on gradients.

Travel with the load in lowest possible position in consideration of the floor clearance under the load.

The load should be moved with lifted fork / platform only for stacking and depositing on even surface.

Travel with steady speed adapted to the load and the floor conditions. For depositing, actuate the parking brake.

Setting the load down

- ⇒ Stop just before the stacking area and lift the load in safe distance over the pile.
- ⇒ Manoeuvre the load directly above the pile.
- ⇒ Lower the load until platform are discharged.
- ⇒ Lower the load by operating the control stick.
- ⇒ Ensure safe reversing, move away and lower the platform.

6. BATTERY

Recommendations for security in relation with the acid of the battery.

The stacker should be put out of function before working on the battery.

Service people:

Read carefully the instructions of use and maintenance, given by the company manufacturing the battery.

Maintenance of the battery:

Be sure pole terminals and cable lug of battery are clean and covered slightly with grease and tightened.

Do not retain discharged batteries. Recharge as soon as possible. Avoid heavy discharge of more than 80% of nominal capacity.

Disposal of the battery:

Please follow carefully national laws and recommendations concerning protection of environment of your country. Also follow battery manufacturer recommendations on this purpose.

Battery charging

Battery should be charged as soon as lifting speed is slowing down, and/or the voltage is less than 10v.

To charge the battery, connect the built-in charger to electric current (110V). The charging is starting automatically, the Power led is on and the display shows the charging current. The charging is finished when the Full led is on.

The electric stacker can be taken into operation again.

The charging time is about 8 to 12 hours while the machine cannot be used. Never leave the built-in charger longer than 24 hours connected.

Never discharge the battery totally (max. discharge 80%), this could damage the battery or even render it useless.



7. MAINTENANCE

7.1 OIL

Please check the oil level every six months. The oil can be hydraulic oil: ISO VG32, its viscosity should be 30cSt at 40° C, total volume is about 2.0lt.

7.2 TO BANISH THE AIR

The air may come into the hydraulic oil because of transportation or pump in upset position. It can cause that the forks do not elevate while pumping in the **RAISE** position. The air can be removed in the following way: let the control handle (FP216) on the **LOWER** position, then move the pedal (FP242) up and down for several times.

7.3 DAILY CHECK AND MAINTENANCE

Daily check of the stacker can limit wear as much as possible. Special attention should be paid to the wheels, the axles, as thread, rags, etc. It may block the wheels. The forks should be unloaded and lowered in the lowest position when the job is over.

7.4 LUBRICATION

All bearings and shafts are provided with long-life grease at the factory. You only need provide with long-life grease at monthly intervals or after each time the truck is cleaned thoroughly to the lubrication points.

7.5. Inspection and maintenance instructions

Safety warning: Before inspection and maintenance work is carried out, appropriate measures should be taken to remove all loads from the platform stacker.

Maintenance and inspection work	Inspection intervals
Check operating elements for faultless operation.	Daily or each time before use
Check condition of the travelling rollers and roller axles	
Check the firmness of the supply and the tension of the chain	
Check the chain, if necessary grease	
Grease joints and bearings	monthly
Check functioning of wheels and rollers	
Check the level of the hydraulic oil with forks completely lowered and the stacker in horizontal position.	Every 3 months
Check hydraulic system for leakage (Is the top lifting height reached effortlessly?)	
Check the adjusting of the lifting chain and of the movement chain, if necessary adjust, clean and grease	
Check the set-up of the control lever	
Check all screw and bolt connections for tightness	
Grease joints and bearings	
Check functioning and turning capability of wheels and rollers	
Check all parts of the hydraulic stacker for wear and replace defective parts where necessary	Annually
Change oil in the hydraulic system (suck the oil out of the tank, refill with new oil) -Ventilate the hydraulic system-	
Check readability of type plate.	
Authorize inspection by competent technical expert	

The service life of your hydraulic stacker is limited. Worn parts must be renewed in good time.

8. TROUBLES SHOOTING

Failure	Cause	Elimination
Motor and hydraulic pump does not operate	Defective fuse FU1 et FU2	Replace the fuse
	Loose or unconnected plug	Reconnect
	Motor is burned out	Replace motor
	K3 switch defective	Replace K 3
The stacker does not lift the load, although the pump is working perfectly	Load is too heavy, overload valve is actuated	Reduce the load
	Lowering valve does not close any more or the valve face is not sealed because of dirt	Clean or replace it
	Without hydraulic oil.	Fill in the oil.
	The oil has impurities.	Change the oil.
The stacker does not lower the load when operating the control stick	The piston rod or mast is deformed resulting from partial loading slanting to one side or over-loading.	Replace with new one.
	The fork / platform was kept in the high position for long time with piston rod bared to arise in rusting and jamming of the rod.	Keeping the fork in the lowest position if not using, and pay more attention to lubricate the rod.
	The release valve of pump is not opened.	Check it, if damaged, replace with new one.
	The fork or other parts are obstructed	Check all moving parts
Raised load is lowered of its own.	Leakage in the hydraulic system	Seal!
	Lowering valve does not close any more or the valve unit is not sealed because of dirt	Clean or replace
	Incorrect valve set-up.	Adjust lowering valve
	Pressure relief valve (pump) is leaky (pump turns slowly backwards.)	Clean or replace the valve
Oil loss on hydraulic cylinder	Sealing elements are worn	Replace sealing elements
The raised load is lowered too slowly	Temperature too low – the hydraulic system oil is too thick	Find a warmer location
Fork / platform does not raise till upper position	Insufficient oil in the tank	Refill with oil (while the fork / platform is lowered)
	Battery discharged	Charge the battery
Battery capacity to low	Battery is not charged enough	Recharge
	Battery is defective	Replace the battery
Battery can not be charged	Fuse FU1 is defective	Replace FU1
	Battery resp. charger defective	Replace battery resp. charger
Too early battery discharge	Silted battery	Replace battery
	Sulphating or other failure in the battery.	Replace battery
	Accidental earth contact in the electric system or battery.	Repair or replace battery

NOTE:

- 1) DO NOT ATTEMP TO REPAIR THE PALLET TRUCK UNLESS YOU ARE TRAINED AND AUTHORIZED TO DO SO.
- 2) After placing out of service, the hydraulic stacker parts must be disposed of or recycled in accordance with legal provisions.

9. Hydraulic Flow Diagram

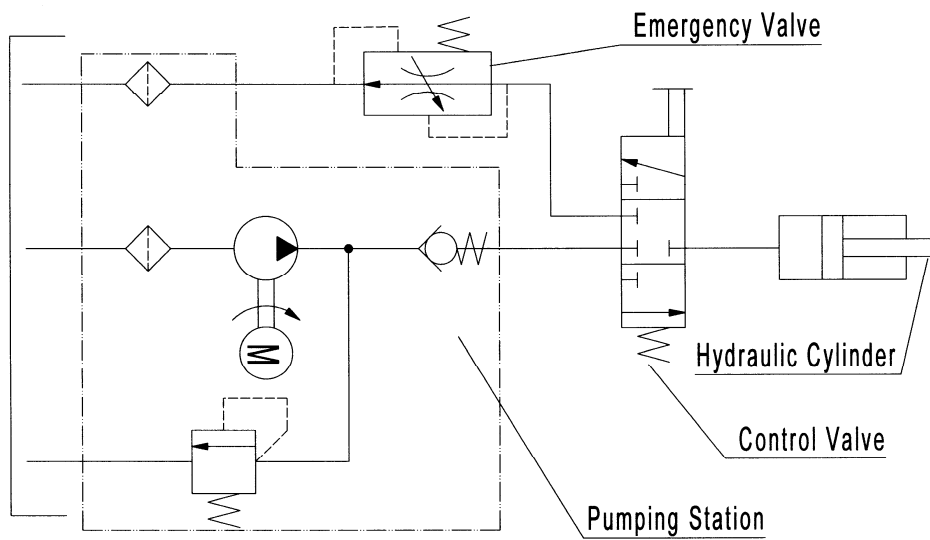

10. CIRCUIT DIAGRAM

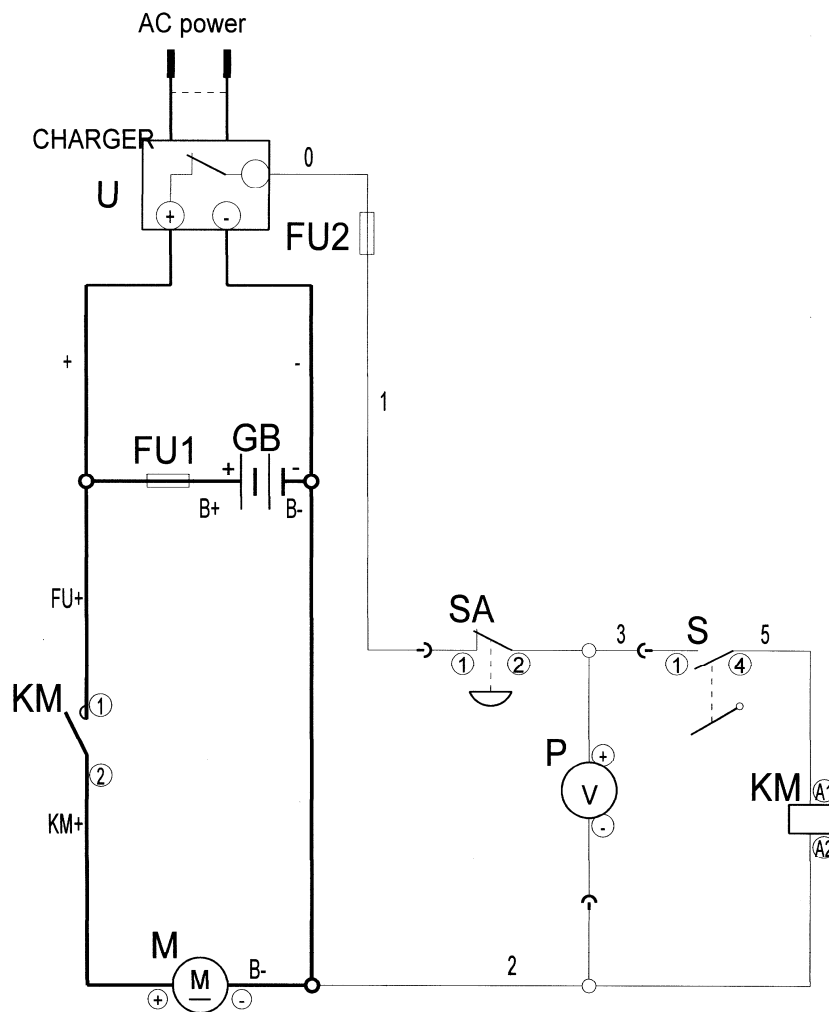

Parts List For EPS0412 and EPS0415

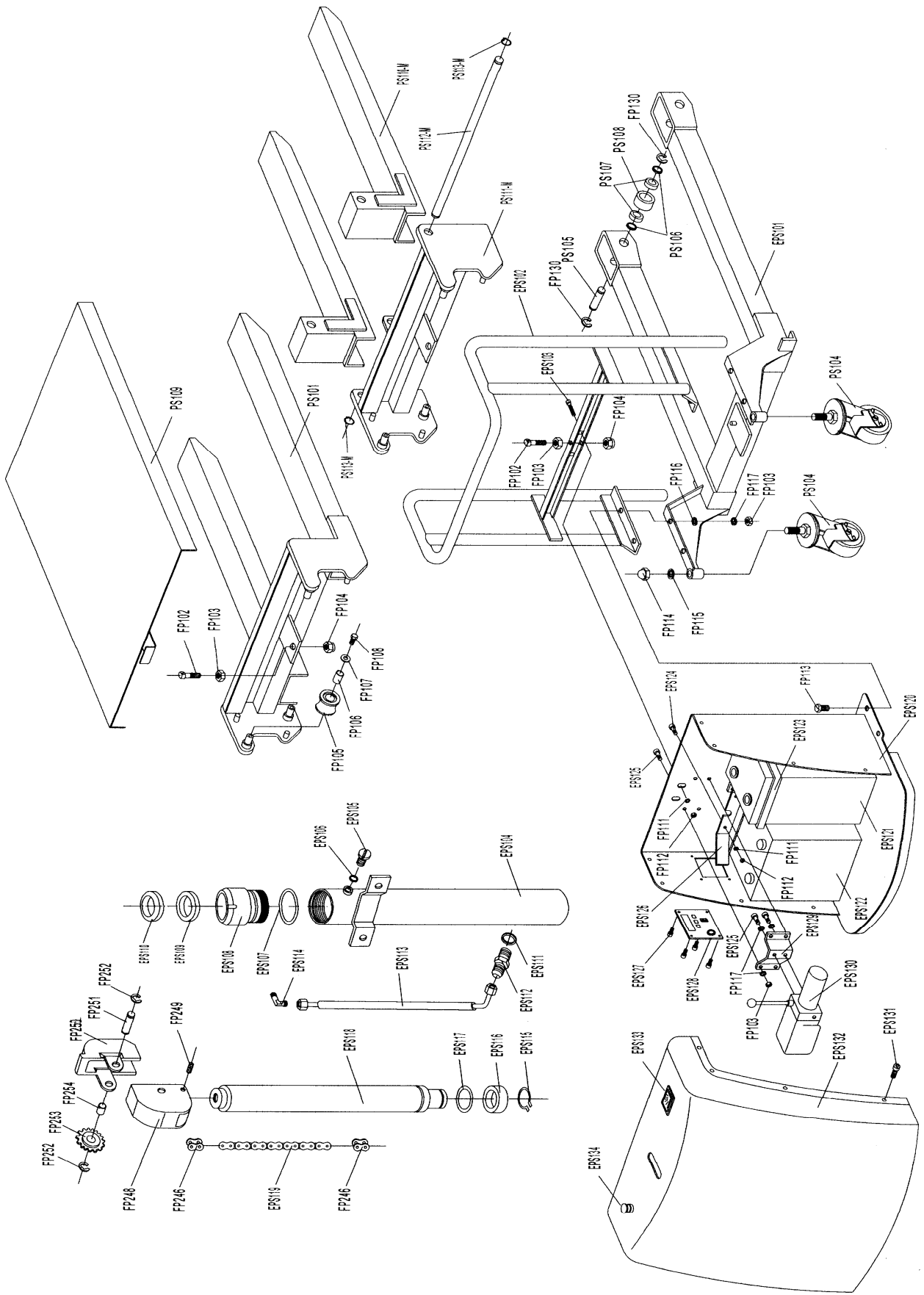

No.	Description	Qty.	No.	Description	Qty.
PS101#	Fork carriage	1	EPS109	Y - ring	1
FP102	Bolt	2	EPS110	Dust ring	1
FP103	Nut	10	EPS111	Seal washer	1
FP104	Nut	2	EPS112	Joint	1
FP105	Roller	4	EPS113	Pipe	1
FP106	Bushing	4	EPS114	90 degree joint	1
FP107	Washer	4	EPS115	Locking ring	1
FP108	Bolt	4	EPS116	Piston	1
EPS102-0412	Mast	1	EPS117	Locking ring	1
EPS102-0415			EPS118-0412	Piston rod	1
EPS103	Screw	2	EPS118-0415		
FP111	Washer	5	EPS119-0412	Chain	1
FP112	Nut	5	EPS119-0415		
FP113	Bolt	4	FP246	Linking Chain	2
FP114	Nut	2	FP248	Cover	1
FP115	Elastic Washer	2	FP249	Bolt	1
FP116	Washer	4	FP250	Cap	1
FP117	Elastic washer	10	FP251	Shaft	1
EPS101	Base body	1	FP252	Locking Ring	2
PS104	Caster	2	FP253	Chain gear	1
FP130	Locking ring	4	FP254	Bushing	2
PS105	Axle for roller	2	EPS120	Electric box	1
PS106	Washer	4	EPS121	Charger	1
PS107	Bearing	4	EPS122	Battery	1
PS108	Roller	2	EPS123	Fixed loop	1
PS109	Platform	1	EPS124	Screw	3
PS110-M*	Fork	2	EPS125	Bolt	6
PS111-M*	Fork Carriage	1	EPS126	Fixed plate	1
PS112-M*	Long shaft	1	EPS127	Screw	4
PS113-M*	Locking ring	2	EPS128	Display for charger	1
EPS104-0412	Cylinder body	1	EPS129	Fixed plate for pump	1
EPS104-0415			EPS130	Pump station	1
EPS105	Screw	1	EPS131	Screw	8
EPS106	Seal washer	1	EPS132	Plastic cover	1
EPS107	O - ring	1	EPS133	Battery indicator	1
EPS108	Screw cover	1	EPS134	Urgent button	1

NOTE: #: for fixed fork; *****: for moved fork.

Parts List For EFP0412 and EFP0415

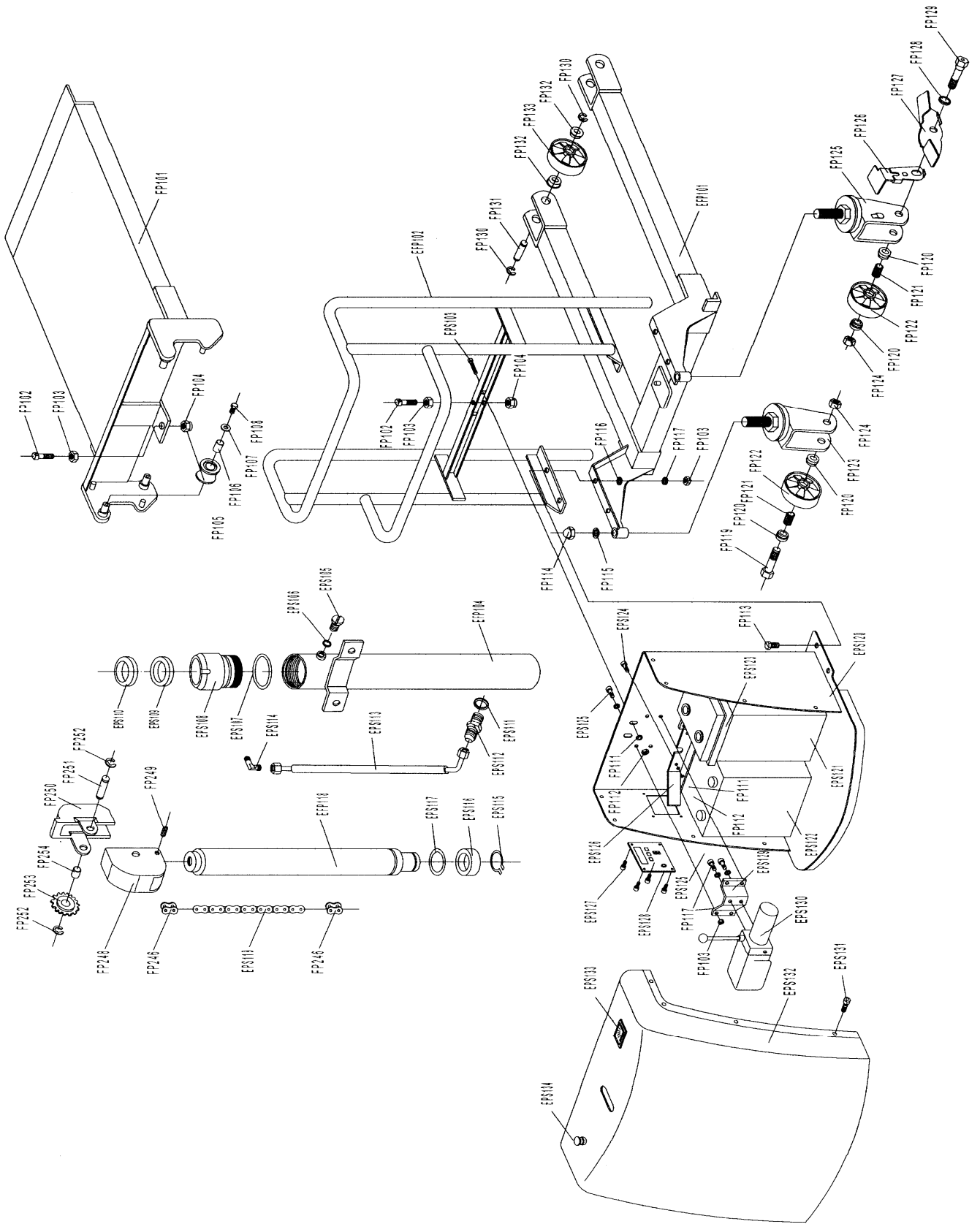

No.	Description	Qty.	No.	Description	Qty.
FP101	Platform	1	EPS108	Screw cover	1
FP102	Bolt	2	EPS109	Y - ring	1
FP103	Nut	10	EPS110	Dust ring	1
FP104	Nut	2	EPS111	Seal washer	1
FP105	Roller	4	EPS112	Joint	1
FP106	Bushing	4	EPS113	Pipe	1
FP107	Washer	4	EPS114	90 degree joint	1
FP108	Bolt	4	EPS115	Locking ring	1
EFP101	Base body	1	EPS116	Piston	1
EFP102-0412	Mast	1	EPS117	Locking ring	1
EFP102-0415			EFP118-0412	Piston rod	1
EPS103	Screw	2	EFP118-0415		
FP111	Washer	5	EPS119-0412	Chain	1
FP112	Nut	5	EPS119-0415		
FP113	Bolt	4	FP246	Linking Chain	2
FP114	Nut	2	FP248	Cover	1
FP115	Elastic Washer	2	FP249	Bolt	1
FP116	Washer	4	FP250	Cap	1
FP117	Elastic washer	10	FP251	Shaft	1
FP119	Bolt	1	FP252	Locking Ring	2
FP120	Washer	4	FP253	Chain gear	1
FP121	Bearing	2	FP254	Bushing	2
FP122	Wheel	2	EPS120	Electric box	1
FP123	Frame of Wheel	1	EPS121	Charger	1
FP124	Nut	2	EPS122	Battery	1
FP125	Frame of Wheel with Brake	1	EPS123	Fixed loop	1
FP126	Brake Plate	1	EPS124	Screw	3
FP127	Footplate	1	EPS125	Bolt	6
FP128	Elastic Washer	1	EPS126	Fixed plate	1
FP129	Bolt	1	EPS127	Screw	4
FP130	Locking Ring	4	EPS128	Display for charger	1
FP131	Shaft	2	EPS129	Fixed plate for pump	1
FP132	Bearing	4	EPS130	Pump station	1
FP133	Loading Roller	2	EPS131	Screw	8
EFP104	Cylinder body	1	EPS132	Plastic cover	1
EPS105	Screw	1	EPS133	Battery indicator	1
EPS106	Seal washer	1	EPS134	Urgent button	1
EPS107	O - ring	1			